



USER'S MANUAL

Windmaster 500

Grid connected wind inverter

This product must be protected externally against over voltages that may occur in no-load and / or extreme wind conditions. Exceeding the specified maximum input voltage must be avoided under any circumstances. Most turbine manufacturers supply a protection circuit to protect power converters from these conditions. Failure to do so may cause serious damage to the inverter and will void product warranty.



MASTERVOLT
Snijdersbergweg 93, 1105 AN Amsterdam
The Netherlands
Tel.: +31-20-342 21 00
Fax: +31-20-697 10 06
www.mastervolt.com



v 1.0 December 2006

WINDMASTER 500

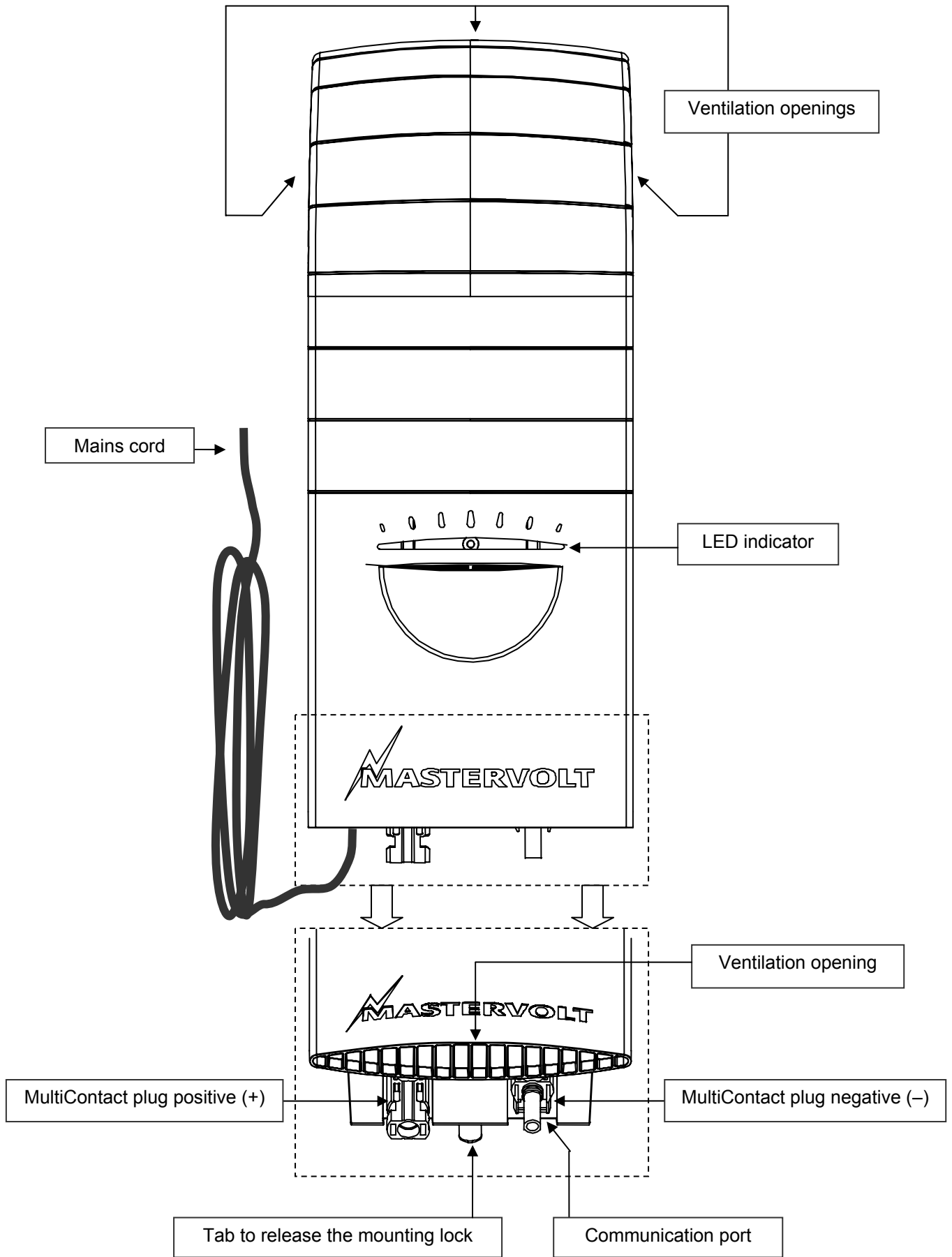

INSTALLATION

1



- Read instructions on page 5 -8 prior to installation.

2

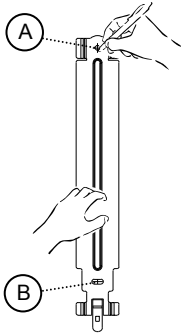

- Mark the position of the two mounting spots A and B by using the mounting bracket

3

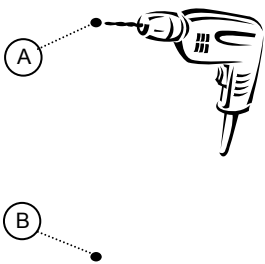

- If necessary, drill mounting holes at spots A and B

4

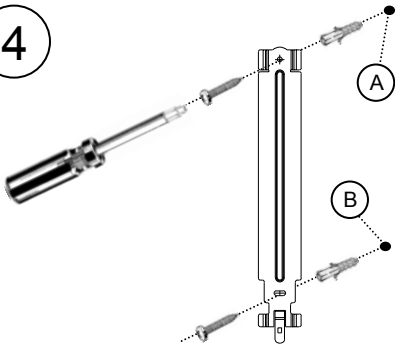

- Fix the mounting bracket to the wall

5

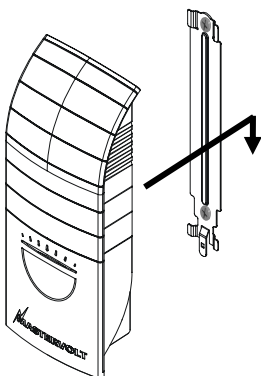

- Place the Windmaster 500 over the mounting bracket and then move it downwards until it is locked by the mounting bracket

INSTALLATION

6

- Check whether the Windmaster 500 is mounted in a secure way.

7

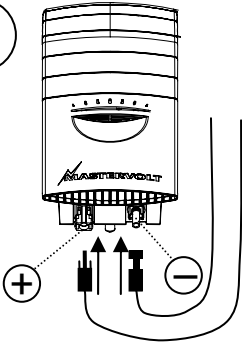

- Connect the string cabling to the Windmaster 500. If wind power is sufficient, the LED indicator will illuminate red.

8

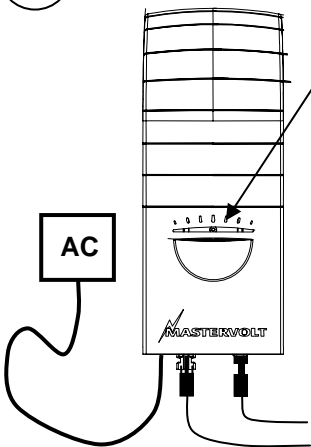

- Connect mains cord to the AC-wiring. Then switch on the grid. If wind power is sufficient, the LED-indicator starts blinking red: the Windmaster 500 is starting up. This may last a few seconds

9

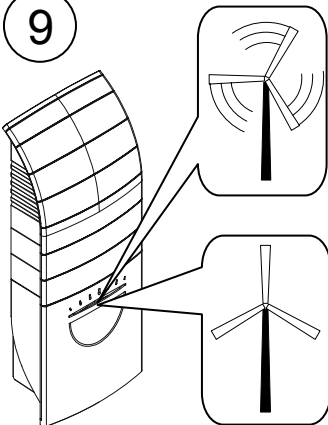

- After starting up, the LED-indicator starts blinking yellow.
- If wind power is too low, the indicator will extinguish

Product description and application

Congratulations for choosing the Mastervolt Windmaster 500. The Windmaster 500 is a inverter for grid connection of small wind turbines. The design is based on the successful Soladin 600 Solar inverter. Windmaster 500 is an “OEM” product and is sold as a part of a system through selected system vendor. The product is to be installed only with selected wind turbines. A system is evaluation by Mastervolt is part of the qualification process.

Unpacking

The delivery consists of the following parts:

- The Windmaster 500 with mounting bracket
- This user’s manual
- MultiContact “Pigtail” adapters (2x)
- Windmaster 500 PC-Link

After unpacking, check the Windmaster 500 for possible damage. Do not use the Windmaster 500 if it is damaged. If in doubt, contact your system vendor.



Safety

Max Input Voltage	150V
Max Input Current	8A
Nom Input Power	550Wdc
Max Short Circuit	12A

- Contact an installer if the wind system does not comply with the above mentioned stipulations. Due to possible high voltages installation and modification may only be carried out by a qualified electrician who is familiar applicable regulations and standards.
- Install the Windmaster 500 according to the instructions stated in this manual.
- Be sure that the Windmaster 500 is disconnected from the grid during installation. This can be done by removing the fuse of the corresponding branch circuit at the AC distribution board
- Connections and safety features must be executed according to the locally applicable regulations
- The Windmaster 500 must be used in accordance with the specifications as stated on page 10
- Never open the housing as high voltages may be present inside!

Choosing the location to install

Obey the following stipulations during installation:

- The Windmaster 500 is suited for indoor use only.
- Ambient temperature: -20 ... 50°C; (power derating above 40°C), Humidity: 0-90% non condensing
- Choose a optimal location to avoid long DC and / or AC wiring to minimize loses.
- Do not install the Windmaster 500 in environments with heavy dust development or humidity.
- If the Windmaster 500 is installed in the immediate vicinity of living areas, take into account that it produces a slight noise level when operating.
- Mount the Windmaster 500 vertically on a solid, non-resonating, wall.
- Mount the Windmaster 500 in such a way that obstruction of the airflow through the ventilation openings is prevented
- No objects must be located within a distance of 20 cm around the Windmaster 500.
- Multiple Windmaster 500 may be mounted next to each other, not above each other. Minimum spacing: 20 cm.

Things you need to install the Windmaster 500

Make sure you have all the parts you need to install the Windmaster 500:

- The Windmaster 500
- Two screws (with plugs) to mount the Windmaster 500. Maximum diameter: 4.5 mm. Use mounting materials which are suitable to carry the weight of the Windmaster 500.
- Tools to fix the screws / bolts with plugs into the wall (screwdriver, drilling machine, a set of drills, a pencil)

Directions for installation

The Windmaster 500 is equipped with a so called “anti-islanding safety device”. It ensures immediate switch off in case of grid failure. European countries maintain different regulations with regard to anti-islanding devices and the supply of energy back to the utility grid in general.

In some countries one single Windmaster 500 may be connected to an existing electricity branch circuit which is fused with 16 Amp. In other countries different restrictions apply. Please acquaint yourself with the local regulations on this issue!

The Windmaster 500 is sold as a part of a system. Your system vendor will provide the Windmaster 500 with the appropriate settings for the local electrical grid. Never connect the Windmaster 500 to a utility grid which is not suitable for use with the apparatus!

During installation you can check by means of the LED-indicator whether the installation is done properly. This check can only be carried out when sufficient wind power is present.

Although the Windmaster 500 is protected against wrong polarity, the positive (+) and negative (-) of the wind turbine connections should not be exchanged.

Install the product according to the instructions stated on page 3 and 4.

Monitoring

The Windmaster 500 has a communication port that can be connected to the COM-port (RS232) of a PC or laptop. Use the provided “Mastervolt PC-link” interface and cable to set up a connection.

Part number	Description
130391030	PC-link Soladin/Windmaster, incl. communication cable, 2m

 **NOTE:** Communication is only possible when sufficient wind power is present.

Operation

After installation the Windmaster 500 will switch on automatically if wind power is sufficient. The Windmaster 500 operates automatically: there is no need for user adjustment or control. The Windmaster 500 has no ON/OFF switch; If necessary remove the fuse from the AC distribution board to switch it off. Do not disconnect the MultiContact plugs during operation of the Windmaster 500! No specific maintenance is required. If necessary, use a soft clean cloth to clean the Windmaster 500. Never use any liquids, acids and/or scourers.

Decommissioning

First remove the Fuse from the AC distribution board before you disconnect the MultiContact plugs. Now the Windmaster 500 can be demounted in a safe way:

1. Push on the lower tab of the mounting bracket to release the mounting lock.
2. Lift the Windmaster 500 upwards for approximately 1 cm.
3. Move the Windmaster 500 straight from the wall

Warranty and Support

The inverter is supplied with a 2-year standard product warranty. Other warranty agreements between system vendor and Mastervolt may apply. First line service and support is performed by the system vendor. Defects caused by DC or AC over voltage, out-of-specification short circuit current, direct or induced lightning and surges as well as cost of travel, installation and energy loss are excluded from product warranty.

Liability

Mastervolt cannot be held liable for:

- Possible errors in this included manual and the consequences of these.
- Use that is inconsistent with the purpose of the product.

Power Curve

The Windmaster 500 converts DC power from a wind turbine to the AC grid based. This conversion is based upon a linear curve with a start voltage and a maximum operating voltage (see figure 1). These parameters may be adjusted and optimized by the system vendor for use with a particular wind turbine. When DC voltage reaches the threshold voltage to start up the Windmaster, the inverter starts a 5 seconds countdown before delivering energy to the AC grid.

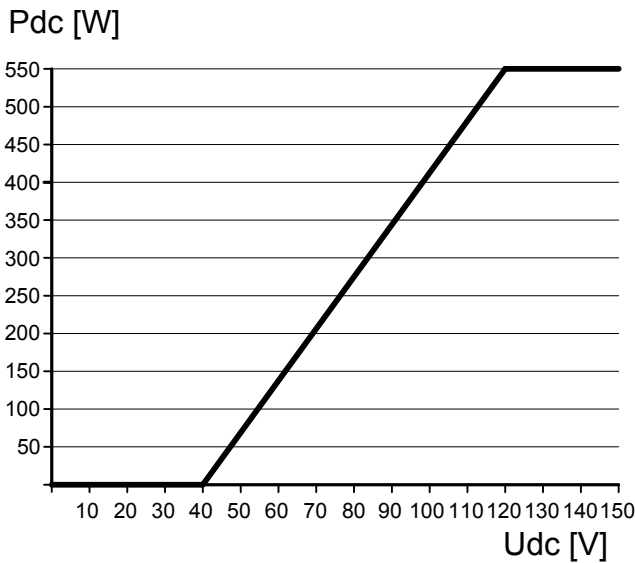

Figure 1

Example installation diagram

See figure 2. This drawing is not specific for any wind turbine or installation. It is provided as a basic reference, showing necessary major components and installation sequence. Please contact your system vendor for detailed installation drawings, specific for you wind turbine.

DC interface

The DC interface is for protection of the Windmaster 500, and should provide the following.

- Surge protection (if applicable)
- Over voltage protection, max. 150VDC (*)
- Disconnection switch (if applicable)

(*) Mechanical either electrical OVP may be integrated in the wind turbine

Grounding

The Windmaster 500 is a class II device with galvanic isolation between DC and AC. The inverter doesn't need to be grounded. Grounding of the Wind turbine however is recommended.

Paralleling

Multiple Windmasters 500 can be operated in parallel to increase output power. The DC-side of each Windmaster 500 must be protected by a 10A (slow blow) fuse (refer to fig. 2).

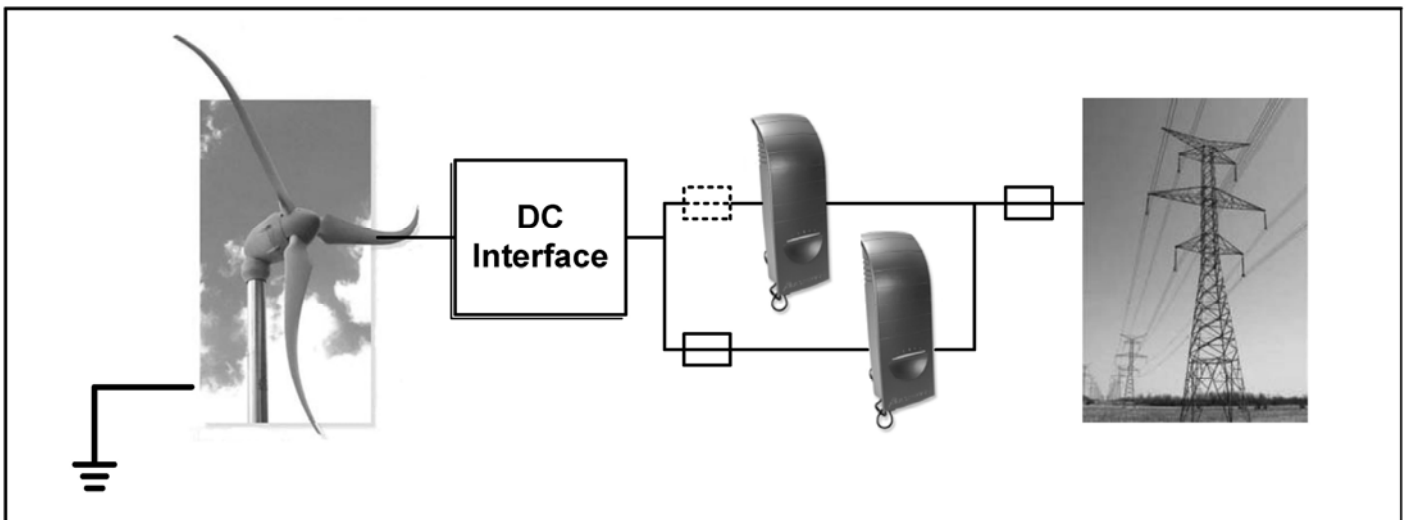

Figure 2

SPECIFICATIONS

Model	Windmaster 500
Part number:	140000500
Manufacturer:	Mastervolt, Amsterdam, the Netherlands
Operating temperature:	-20°C to 50°C (full power up to 40°C)
Storage temperature:	-20°C to 70°C
Relative humidity:	Max. 95%, non condensing (electronics have anti-moisture coating)
Protection degree:	IP23 (for indoor use)
Safety class:	Class II Double insulated
Galvanic isolation	Class II HF transformer
Dimensions (H x W x D):	365 x 143 x 75 mm
Weight:	Approx. 2 kg.
Enclosure:	UL 5V fire retardant ABS/PC
Mounting	Wall mounting bracket included

Input (DC)	
Nominal power:	550WDC
Operating voltage range:	35-150 VDC
Full power voltage range:	65-125 VDC
Max current:	8A
Max short current:	12A
Start-up power:	1W
Connectors:	MultiContact 4mm type connectors ; adapters are included

Paralleling	Multiple units can be operated in parallel to increase output power The DC-input of each unit must be protected by a 10A DC (slow blow) fuse
--------------------	-------------------------------------------------------------------------------------------------------------------------------------------------

Output	
Voltage:	230V (185V-264V)
Nominal power:	525W
Nominal current:	2,25A
Fuse:	3,15A -T
Frequency:	50 Hz (48-52 Hz)
Cos phi:	0,99
Stand-by power:	< 0,05Wac
Maximum efficiency:	93%
Mains cord:	1,8 meter of AC wire

Safety Functions	
Anti-Islanding	Voltage- and frequency window; frequency shift G83 compliant
Over temperature	Power derating at > 40 °C; switch off at internal over temperature
Polarity	Protected against inverse polarity
Surges	Protected against AC and DC surges caused by indirect lightning strike

User Interface	
Front indicator	Dual color (yellow/red)
Normal operation	Yellow blinking (faster blinking = higher power)
Fault indication	Red flashing (6 different codes)
Communication	PC-Link adapter and cable for RS-232 communication included. PC software downloadable from www.mastervolt.com

National grid connection regulations	
Approvals:	G83 (GB); NTA 8493 (Netherlands)
Country compatibility	Standard suitable for all 230V / 50 HZ countries. Country specific settings programmable. External ENS may be required for some countries (contact your local distribution network operator for local grid connection requirements)

DIMENSIONS

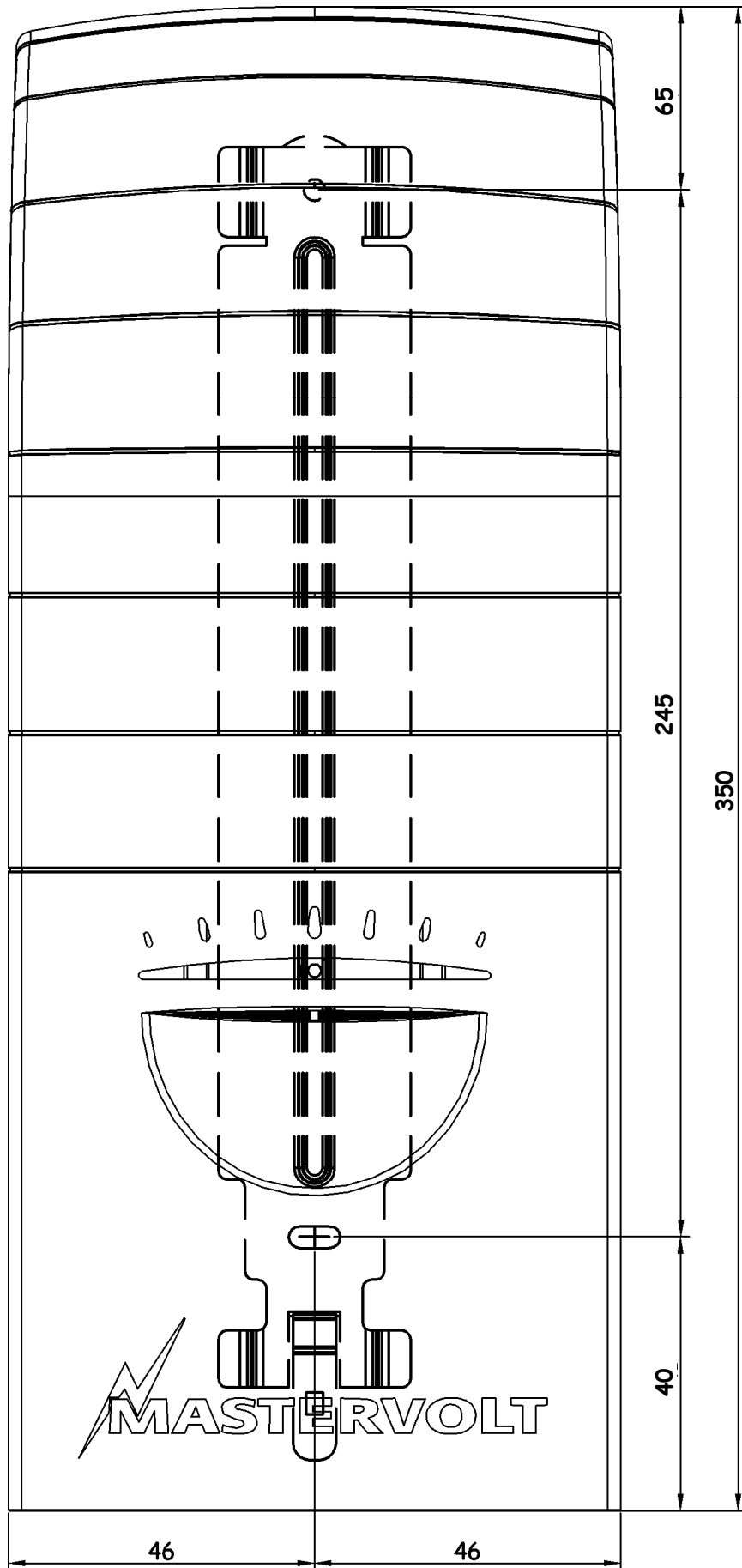

CE DECLARATION OF CONFIRMITY

Manufacturer: Mastervolt

Address: Snijdersbergweg 93
1105 AN Amsterdam
The Netherlands



Herewith declares that:

Product: Windmaster 500

Is CE-marked and complies with the following standards:

EMC directive 89/336/EEC
Environment: residential, commercial and light industrial

Emission

Emission - class B: EN 55022: 1998
harmonic current emission: EN 61000-3-2: 2000

Immunity

Generic immunity standard: EN 61000-6-2: 2001
Electrostatic discharge (ESD): EN 61000-4-2: 1995
Radiated EMC: EN 61000-4-3: 1996
Electrical fast transients (EFT) : EN 61000-4-4: 1995
Surge transient : EN 61000-4-5: 1995
Conducted RF disturbances : EN 61000-4-6: 1996
Voltage dips and short interrupts : EN 61000-4-11: 1994
Digital radio telephones : ENV 50204: 1995

Safety

Low Voltage directive : LV 73/23 EEC
Electrical safety : EN 60950 : 2003

Amsterdam,

R.J. ter Heide,
General Manager MASTERVOLT



© Mastervolt BV, Snijdersbergweg 93, 1105 AN Amsterdam, Netherlands
Tel: + 31-20-3422100 Fax: + 31-20-6971006 Email: info@mastervolt.com